

PRODUCT / PRODUKT / PRODUCT / PRODUIT

VERPAKKING / VERPACKUNG  
PACKING / EMBALLAGE

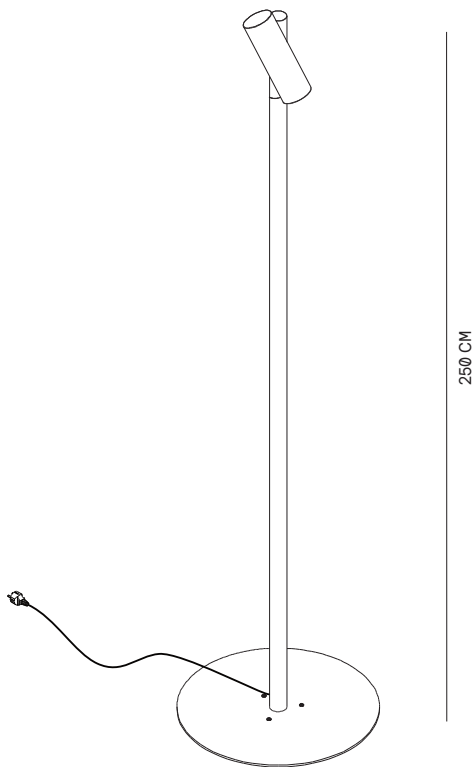

230V 12W IP44 CE   

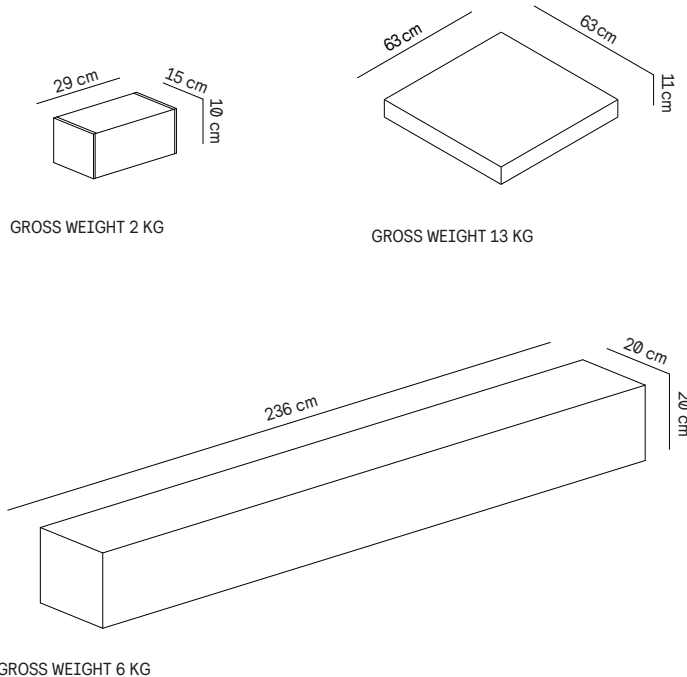

SPECIFICATIES

SPEZIFIKATIONS

SPECIFICATIONS

SPECIFICATIONS

220-240V/50-60Hz  
Vermogen armatuur 12W  
Klasse I armatuur  
IP44, beschermt tegen stof en is plensdicht.  
Gewicht: 1,8 KG  
CE - Conform marking  
Voldoet aan de EU richtlijn 2002/96/EC

220-240V/50-60Hz  
Anschlussleistung 12W  
Schutzklasse I  
Schutzart IP 44, schützt vor Staub und ist spritzwassergeschützt.  
Gewicht: 1,8 KG  
CE - Konformitätszeichen  
Dieses Product entspricht der EUR ichtlinie 2002/96/EC

220-240V/50-60Hz  
Luminaire wattage 12W  
Safety class I  
Protection class IP 44, protects against dust and is splash-proof.  
Weight: 1,8 KG  
CE - Conformity mark  
This product complies with EU Directive 2002/96/EC

220-240V/50-60Hz  
Puissance raccordée 12W  
Classe de protection I  
Degré de protection IP 44, protège de la poussière et des éclaboussures.  
Le poids: 1,8 KG  
CE - Sigle de conformité  
Ce produit est conforme a la Directive ED 2002/96/EC

VEILIGHEID

SICHERHEIT

SAFETY INDICES





SECURITE

De fabrikant is ontslagen van zijn aansprakelijkheid, wanneer de schade is veroorzaakt door oneigenlijk gebruik of installatie. Als een armatuur is gemodificeerd wordt de personen verantwoordelijk voor de modificatie beschouwd als fabrikant.

Der Hersteller übernimmt keine Haftung für Schäden, die durch unsachgemäßen Einsatz oder Montage entstehen. Werden nachträglich Änderungen an der Leuchte vorgenommen, so gilt derjenige als Hersteller, der diese Änderungen vornimmt.

The manufacturer is then discharged from liability when damage is caused by improper use or installation. If any luminaire is subsequently modified, the persons responsible for the modification shall be considered as manufacturer.

Le fabricant décline toute responsabilité résultant d'une mise en œuvre ou d'une installation inappropriée du produit. Toutes les modifications apportées au luminaire se feront sous la responsabilité exclusive de celui qui les effectuera.

INSTALLATIE	INSTALLATION	INSTALATTION	L'INSTALLATION
 <p>Zorg voor een goede verankering bij omstandigheden waar veel wind kan worden verwacht!</p>	 <p>Achten Sie auf eine gute Verankerung bei starkem Wind!</p>	 <p>Ensure good anchoring in circumstances where a lot of wind can be expected!</p>	 <p>Assurez un bon ancrage dans des conditions de vent fort!</p>

