

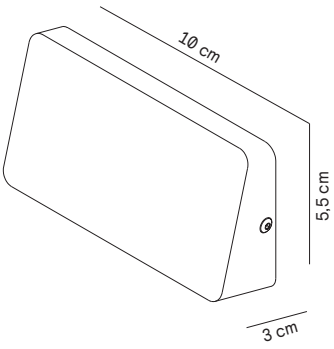







<p>PRODUCT / PRODUKT / PRODUCT / PRODUIT</p>  <p>24V DC 2.6W IP65   </p>	<p>VERBINDING KABEL / VERBINDUNGKABEL / CONNECTION CABLE / CABLE DE CONNEXION</p> 	<p>VERPAKKING / VERPACKUNG / PACKING / EMBALLAGE</p>  <p>GROSS WEIGHT 0,3 KG</p>
--	--	---

SPECIFICATIES	SPEZIFIKATIONS	SPECIFICATIONS	SPECIFICATIONS
<p>24V DC Vermogen armatuur 2.6W Klasse III armatuur IP65.</p> <p>Gewicht: 0,3 KG  - Conform marking Voldoet aan de EU richtlijn 2002/96/EC</p>	<p>24V DC Anschlussleistung 2.6W Schutzklasse III Schutzart IP 65.</p> <p>Gewicht: 0,3 KG  - Konformitätszeichen Dieses Product entspricht der EUR ichtlinie 2002/96/EC</p>	<p>24V DC Luminaire wattage 2.6W Safety class III Protection class IP 65.</p> <p>Weight: 0,3 KG  - Conformity mark This product complies with EU Directive 2002/96/EC</p>	<p>24V DC Puissance raccordée 26W Classe de protection III Degré de protection IP 65.</p> <p>Le poids: 0,3 KG  - Sigle de conformité Ce produit est conforme a la Directive ED 2002/96/EC</p>

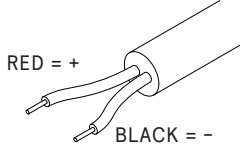
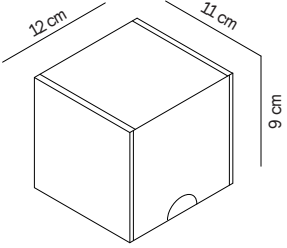
VEILIGHEID	SICHERHEIT	SAFETY INDICES	SECURITE
<p>De fabrikant is ontslagen van zijn aansprakelijkheid, wanneer de schade is veroorzaakt door oneigenlijk gebruik of installatie. Als een armatuur is gemodificeerd, de personen verantwoordelijk voor de modificatie moet worden beschouwd als fabrikant.</p>	<p>Der Hersteller übernimmt keine Haftung für Schäden, die durch unsachgemäßen Einsatz oder Montage entstehen. Werden nachträglich Änderungen an der Leuchte vorgenommen, so gilt derjenige als Hersteller, der diese Änderungen vornimmt.</p>	<p>The manufacturer is then discharged from liability when damage is caused by improper use or installation. If any luminaire is subsequently modified, the persons responsible for the modification shall be considered as manufacturer.</p>	<p>Le fabricant décline toute responsabilité résultant d'une mise en œuvre ou d'une installation inappropriée du produit. Toutes les modifications apportées au luminaire se feront sous la responsabilité exclusive de celui qui les effectuera.</p>

INSTALLATIE	ISTALLATIE	INSTALATTION	L'INSTALLATION
---	---	---	---

EDDY

AFMETINGEN / ABMESSUNGEN / DIMENSIONS / DIMENSIONS

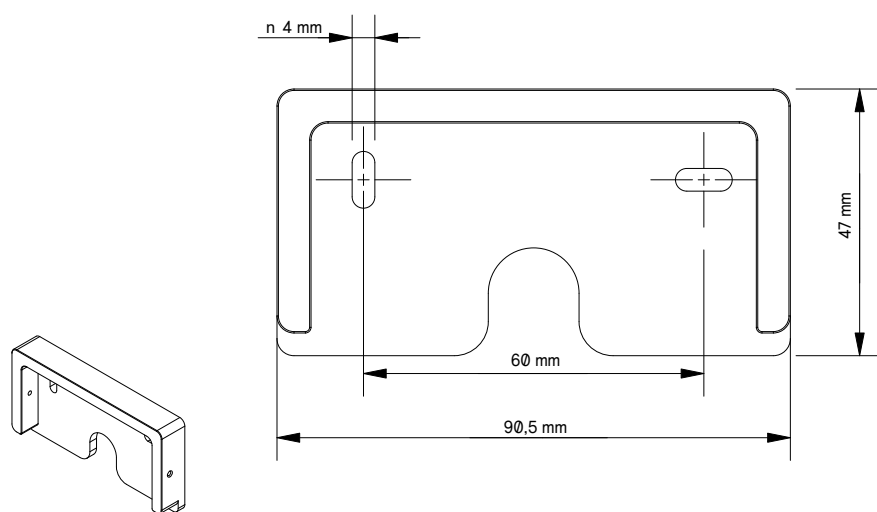

UNDO MOUNTING MATERIAL

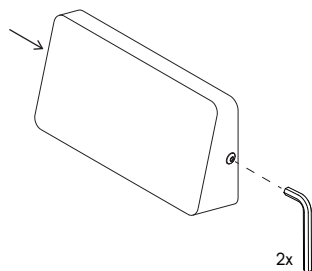

INSTALATION

